



A valmont BRAND

Highway Safety, Marking, and Traffic Control Products





Who we are

With more than 30 years of experience serving highway, utility, and federal recreation markets, Carsonite has developed distinctive products and applications geared to each market. Our posts offer the maximum in durability and flexibility to address vehicle impacts and a variety of soil conditions. Carsonite posts are engineered to enhance visibility, simplify installation, withstand the elements and increase safety.

Our markers and delineators are the industry standard. Many of the marking products in wide use today are based on Carsonite patents. Our trademarked profiles remain the standard by which all other markers are measured, and Carsonite's easily identifiable products are manufactured and assembled in the United States.

Carsonite is committed to excellence. Our name appears on all of our products, and we are dedicated to customer service. Our sales representatives and a vast distribution network stand ready to serve you with quality products and timely delivery.

Highway Safety, Marking, and Traffic Control Products

Roadmarker™ (CRM)	2
Curv-Flex™ (CFR)	3
Dual Sided Marker (CIB)	4
Tuff-Flex™ (CTFM)	5
Visibility Enhancer (CVE)	6
Visibility Enhancer Unit (CVE3)	7
Snow Poles (SNFB)	8
Pedestal Marker (PM)	9
Boundary Marker (CBM)	10
Survivor™ (CDS)	11
GreenLine™ Single Curve Markers (CGD)	12
FlexGuard™ (CFG)	13
Super Duck™ (SDR3)	14
Twist Lock Channelizer™ (TLC)	15
The Channelizer™ (SDC)	16
Cable Guardrail Delineator™ (GCGR)	17
Guardrail Delineator™ (CGR)	18
Reflective Sign Support Cover (RSC)	19
Guard Post Cover (IGP)	20
Support Post (CSP).....	21
Sign Support Post (CSS)	22
Hazard Marker Unit (HM).....	23
Carsonite Standard and Custom Signs	24-26
Reflective Sheeting	27
Carsonite Decals	28-29
Modular Guidance System™ (MGS)	30-31
Carsonite AcoustaShield™ Sound Barriers	32-35
Installation Tools	36
Anchor Barb Kit	Inside Back Cover



19845 U.S. Highway 76
Newberry, South Carolina 29108
800-648-7916 · www.carsonite.com

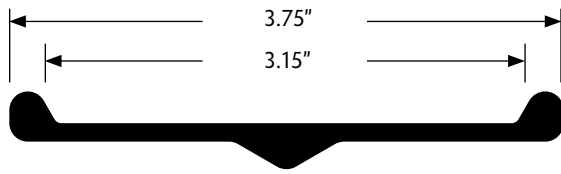

Withstands highway-speed vehicle impacts

The Roadmarker, with its three-rail design was the first fiberglass composite highway marker in the industry and remains the most popular marker in the market. Two ribs on the side protect sheeting from vehicle impacts while the back rib gives added strength for driving into hard soil conditions.

How to Order:

CRM 3
Product number

072
Length (in.)
See chart for availability by color.

Color (See chart below)

01

Post color	Standard Lengths (in.)
01-White	60, 62, 66, 72, 84
02-Yellow	60, 62, 66, 72
03-Brown	72
04-Orange	60, 62, 66, 72
05-Red	60, 62, 66
07-Green	72
08-Blue	66

Other lengths and colors are available. Contact your representative.

Material: Fiberglass Composite, high-performance construction

Options and Accessories: Reflective sheeting
Stock or custom decals
Direct Graphics
Visibility Enhancer
Anchor Barb

Installation tools: Post Driver (PDR, PDRL)
Post Puller
Pilot Hole Driver

Carsonite High Performance RoadMarkers are designed to stand up to nature as well as vehicular impacts, controlled ditch burns, and even small arms gunfire.



Curv-Flex™ Marker

CFR

Drivable, flexible, impact resistant marker

Our most flexible fiberglass composite marker. The Curv-Flex is recommended for areas where vehicle impacts are likely. With its trademarked curve and flange profile, the Curv-Flex marker withstands direct tire impacts. In dense soil conditions, the Curv-Flex may require a small pilot hole before installation.

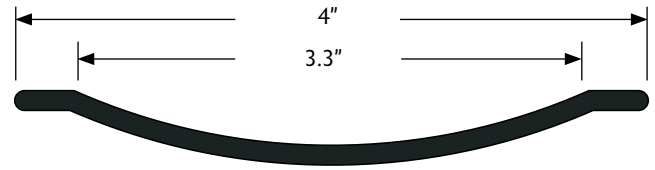

How to Order:

CFR4
Product number

062
Length (in.)
See chart for availability by color.

Color (See chart below)

01

Post color	Standard Lengths (in.)
01-White	27, 60, 62, 66

Other lengths and colors are available. Contact your representative.

Material: Fiberglass Composite

Options and Accessories: Reflective sheeting
Stock or custom decals
Anchor Barb

Installation tools: Post Driver (PDR, PDRL)
Post Puller
Pilot Hole Driver
Guide Tube



Dual Sided Marker

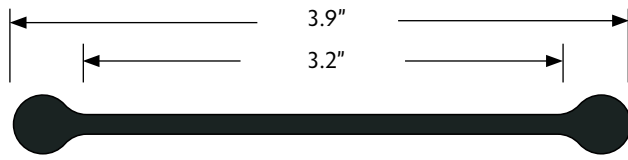

Durable, attractive two-sided marker

This durable fiberglass composite Carsonite Dual Sided Marker accepts sheeting on both sides and is the ideal marker for conveying 180-degree messages or for rural route marking or 9-1-1 identification.

How to Order:

CIB3
Product number

066
Length (in.)
See chart for availability by color.

Color (See chart below)

01

Post color	Standard Lengths (in.)
01-White	60, 62, 66
03-Brown	60, 62, 66, 72

Other lengths and colors are available. Contact your representative.

Material: Fiberglass Composite

Options and Accessories: Reflective sheeting
Stock or custom decals
Direct Graphics
Visibility Enhancer
Anchor Barb

Installation tools: Post Driver (PDR, PDRL)
Post Puller
Pilot Hole Driver



Tuff-Flex™ Marker

CTFM

Designed for two-sided messages and hard soils This

fiberglass composite marker offers all of the benefits of the Dual Sided Marker, with additional rigidity. With its thickened center rib, it remains drivable in virtually any soil condition. Excellent for 180-degree visibility.

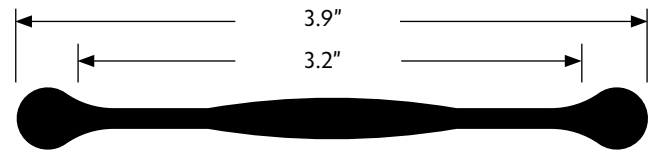

How to Order:

CTFM

Product number

060

Length (in.)

See chart for availability by color.

Color (See chart below)

05

Post color	Standard Lengths (in.)
02–Yellow	60, 62, 66, 72
04–Orange	60, 62, 66, 72
05–Red	60, 62, 66, 72
08–Blue	60, 62, 66, 72

Other lengths and colors are available. Contact your representative.

Material:

Fiberglass Composite

- Options and Accessories: Reflective sheeting
 Stock or custom decals
 Visibility Enhancer
 Anchor Barb
- Installation tools: Post Driver (PDR, PDRL)
 Post Puller
 Pilot Hole Driver



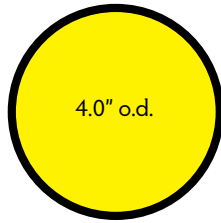

How to Order:

CVE3

Product number

021

Length (in.)
See chart for availability by color.

Color (See chart below)

02

Post color	Standard Lengths (in.)
01-White	21
02-Yellow	21
04-Orange	21

Material: Polypropylene

Options and Accessories: Reflective sheeting
Stock or custom decals

360-degree sleeve

Convert Carsonite's flat fiberglass composite markers to 360-degree posts by adding a Visibility Enhancer. Easily retrofitted in the field, the enhancers fit Carsonite's RoadMarker™ (CRM), Dual Sided (CIB) and Tuff-Flex™ Markers (CTFM). Available in white, yellow or orange. The sheeting area is 17" high.

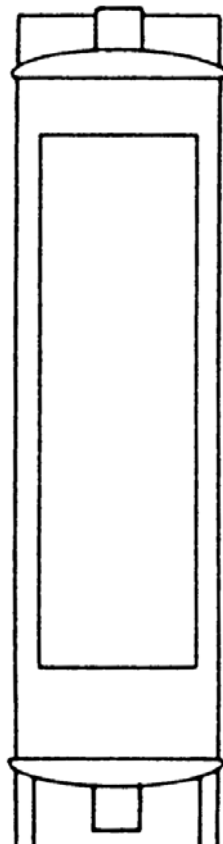

Visibility Enhancer™ Unit

CVE3

Carsonite RoadMarker™ with Visibility Enhancer

When ordered as unit, the Visibility Enhancer is shipped from the factory with a pre-drilled RoadMarker (CRM) standard for ease of installation. Apply reflective sheeting to increase visibility.

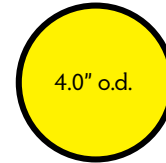
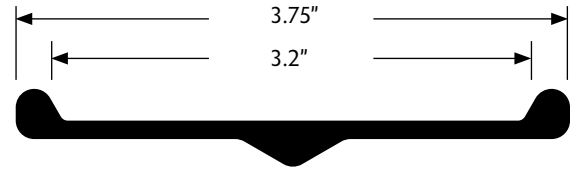

How to Order:

CVE3

Product number

072

Post length (in.)

See chart for availability by color.

Other post lengths and colors are available. Contact your representative.

Post Color (See chart below)

01

Enhancer Color (See chart below)

02

Post color	Standard Lengths (in.)
01-White	60, 62, 66, 72, 84
02-Yellow	60, 62, 66, 72
03-Brown	72
04-Orange	60, 62, 66, 72
05-Red	60, 62, 66
07-Green	72

Enhancer color	Standard Length (in.)
01-White	21
02-Yellow	21
04-Orange	21

Material:

Post: Fiberglass Composite
Enhancer: Polypropylene

Options and Accessories:

Reflective sheeting
Stock or custom decals
Anchor Barb

Installation tools:

Post Driver (PDR, PDRL)
Post Puller
Pilot Hole Driver



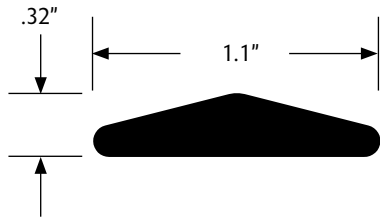

How to Order:

S F N B

Product number

072

Length (in.)

See chart for availability by color.

Post Color (See chart below)

04

Add U for optional Grommet

U

Color	Standard Lengths (in.)
04-Orange	72, 84, 96

Other lengths and colors are available. Contact your representative.

Material: Fiberglass Composite

Options and Accessories: Reflective sheeting
Stock or custom decals
Grommets (for existing U-channel)

Installation tools: Post Driver (DP1000)
Post Puller
Pilot Hole Driver

High visibility in all snowscapes

These composite markers add visibility to installed utilities to act as warnings to motorists and snow plows during heavy snowfall. Add reflective sheeting to increase visibility. Add grommets (sold separately) to install in existing U-channels.



Pedestal Marker

PM

Versatile, durable and visible

The pedestal marker is Carsonite's reliable snow pole with a bracket attached that allows easy attachment to existing pedestal installations, provide high visibility during periods of snowfall to motorists and snow plows.

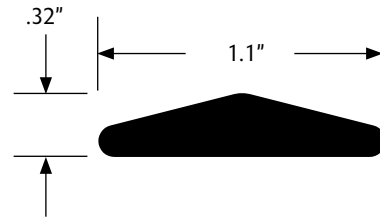
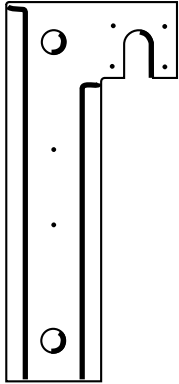

How to Order:

PM 12
Product number

072
Length (in.)
See chart for availability by color.

Color (See chart below)

04

Color	Standard Lengths (in.)
04-Orange	72, 84, 96

Other lengths and colors are available. Contact your representative.

Material: Fiberglass Composite
Options and Accessories: Reflective sheeting
Stock or custom decals



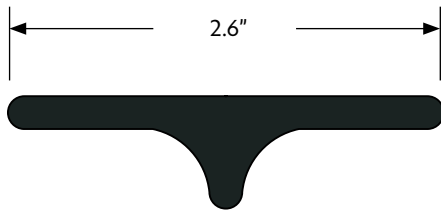

Excellent for pedestals and enclosures

The Carsonite Boundary Marker post is a rigid composite post that can be driven in virtually any soil conditions. When cost is a concern, this economical marker is an ideal solution.

How to Order:

CBM 2

Product number

062

Length (in.)

See chart for availability by color.

Other lengths and colors are available. Contact your representative.

Color (See chart below)

04

Color	Standard Lengths (in.)
04-Orange	48, 60, 62, 66, 72

- Material: Fiberglass Composite
- Options and Accessories: Stock or custom decals
Reflective sheeting
- Installation tools: Post Driver (D250)
Post Puller
Pilot Hole Driver



Versatile, durable and visible

One of Carsonite's most durable posts. This polymer post with integral metal U-channel is easily driven into all types of soils. For use in areas where impacts are likely, this post has been impact tested at speeds of 65 mph.

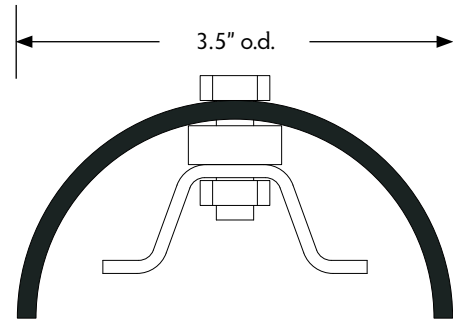
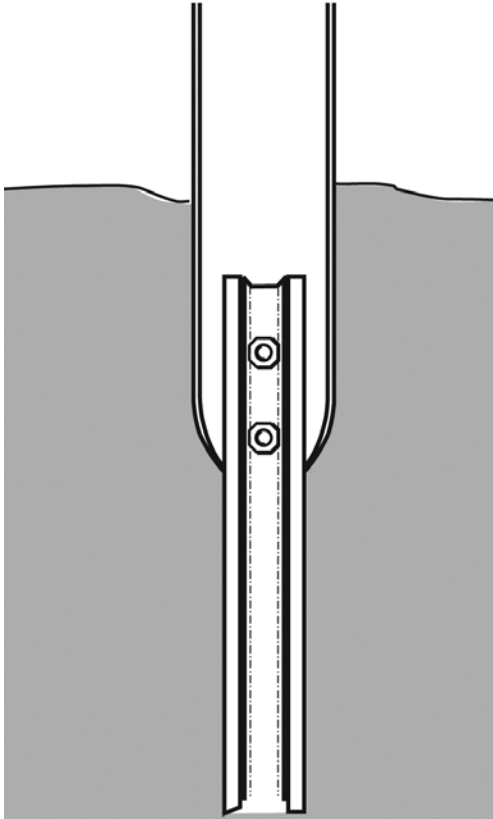

How to Order:

CDS3
Product number

066
Length (in.)
See chart for availability by color.

Color (See chart below)

01

Color	Standard Lengths (in.)
01-White	66
02-Yellow	66
09-Gray	66

Other lengths and colors are available. Contact your representative.

Material: Polypropylene

Options and Accessories: Reflective sheeting

Stock or custom decals

Installation tools:

U-channel Driver (D300)



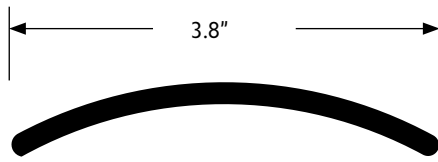

Flexible, durable and visible

The GreenLine Single-Curve Marker is a highly flexible post featuring a simple, curved design that will take direct tire impacts at highway speeds. Available in bright colors, this attractive marker is ideal for 9-1-1 and yard marker applications. Decals or reflective sheeting can be applied to both sides. For hard soils, a convenient metal U-channel anchor may be added.

How to Order:

CGD1
Product number

060
Length (in.)
See chart for availability by color.

Color
(See chart below)

01

Add U for optional U-channel

U

Color	Standard Lengths (in.)
01-White	60, 66
02-Yellow	60, 66

Other lengths and colors are available. Contact your representative.

- Material:** Polycarbonate
-
- Options and Accessories:** Reflective sheeting
Stock or custom decals
Anchor Barb
- Installation tools:** Post Driver (PDR, PDRL)
Guide Tube
Post Puller
Pilot Hole Driver
U-channel Driver



Versatile, durable and visible

The FlexGuard is a two-part post system consisting of a drivable metal anchor and an ikmpact resistant, flexible post. The top of the post may be round, to support bands of reflective sheeting, or flattened, to support 3" wide strips of sheeting.

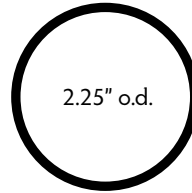

2.25" o.d.

Round

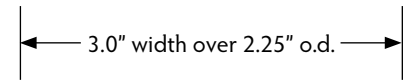

3.0" width over 2.25" o.d.

Flat

How to Order:

CFG2

Product number

CFGF-Flat
CFG2-Round

066

Length (in.)

See chart for availability by color.

Color (See chart below)

01

Color	Standard Lengths (in.)
01-White	66
02-Yellow	66

Other lengths and colors are available. Contact your representative.

- Material:** Polypropylene
- Options and Accessories:** Reflective sheeting
Stock or custom decals
- Installation tools:** Sentry Socket Driver (SMD)



SDR3

Super Duck™

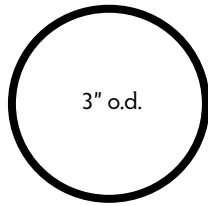

3" o.d.

How to Order:

SDR3

Product number

036

Length (in.)

Color
(See chart below)

01

Color	Standard Lengths (in.)
01-White	36
02-Yellow	36
04-Orange	36

Surface-mounted, Impact-resistant Delineator

This unique 3" channelizer supports up to 6 bands of reflective sheeting. Ideal for construction sites, lane changes, and adding visibility to raised medians.



Material: Polypropylene
Base: Rubber

Options and Accessories: Reflective sheeting
Stock or custom decals
Mastic Pad



NEW

The Twist Lock Channelizer™

TLC

Surface-mounted, Impact-resistant delineator with Quick-Change Twist Lock post and base

Carsonite's 3" Twist Lock Channelizer puts the emphasis on safety in high-traffic areas. The highly visible, durable, polyurethane post stands up to repeated abuse in high-traffic interchanges. Its base and quick-change collet are built to withstand repeated vehicular impacts at high speeds, as well as repeated, direct tire rollover. The best part is the Twist Lock design. No tools required to change the post. Simply push and twist to snap a new post into the base. And you're out of there.

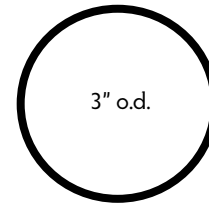

How to Order:

T L C 3
Product number

036
Length (in.)
See chart for availability by color

Color
(See chart below)
04

Color	Standard Lengths (in.)
01-White	36, 42
02-Yellow	36, 42
04-Orange	36, 42

Other lengths and colors available. Contact your representative.

- Material: Polyurethane
Base & Collet: Composite
-
- Options and Accessories: Reflective sheeting
Stock or custom decals
Mastic Pad
Spare posts as replacement parts

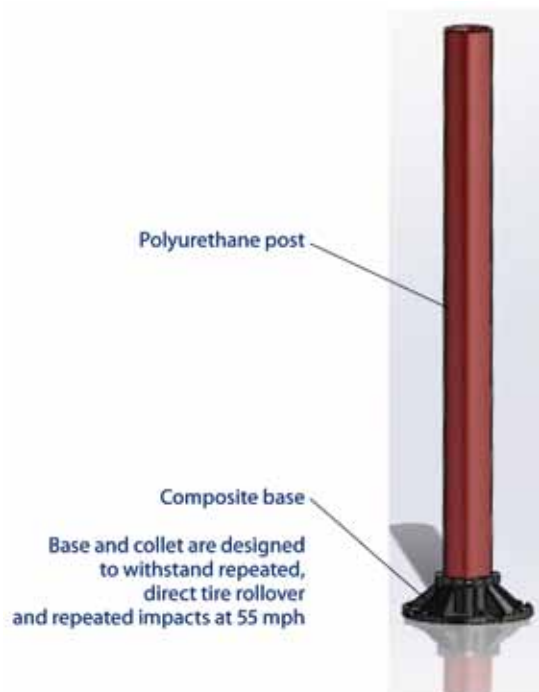

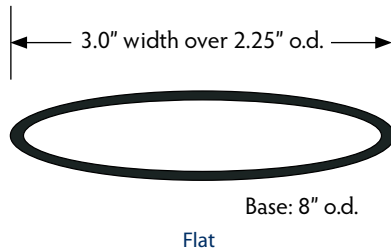
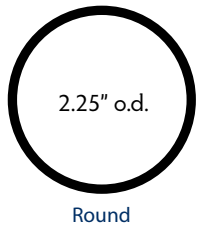

Surface mounted, impact-resistant delineator

Carsonite's 2.25" Channelizer. The top of the post may be round for bands of sheeting or flattened to support strips of reflective sheeting up to 3" wide. The Channelizer provides excellent delineation to high-traffic interchanges.

How to Order:

Round-2
Flattened-F

Color
(See chart below)

S D C **2** **036** **01**

Product number Length (in.)

See chart for availability by color.

Color	Standard Lengths (in.)
01-White	36, 42
02-Yellow	36, 42
04-Orange	36, 42

Other lengths and colors are available. Contact your representative.

- Material:** Polypropylene
Base: Natural Rubber
-
- Options and Accessories:** Reflective sheeting
Stock or custom decals
Mastic Pad

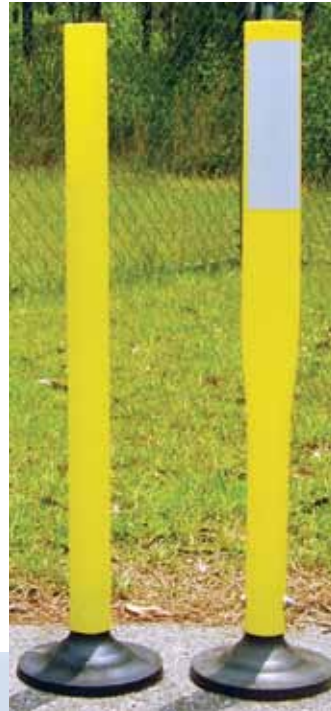

Cable Guardrail Delineator™

GCGR

For cable guardrails

Designed for easy installation on cable guardrails, these recycled dual sided delineators can be attached to steel supports with double sided tape. Also available with holes for attachment to wood and other structures.

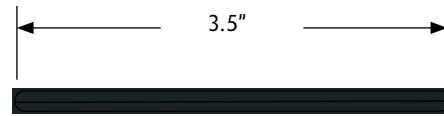

How to Order:

GCGR 3014 01

Product number

Color	Standard Lengths (in.)
01-White	14

Other lengths and colors are available. Contact your representative.

Reflective sheeting sold separately.

Material: Polycarbonate
Options and Accessories: Reflective sheeting
Stock or custom decals
Double-sided Adhesive Tape

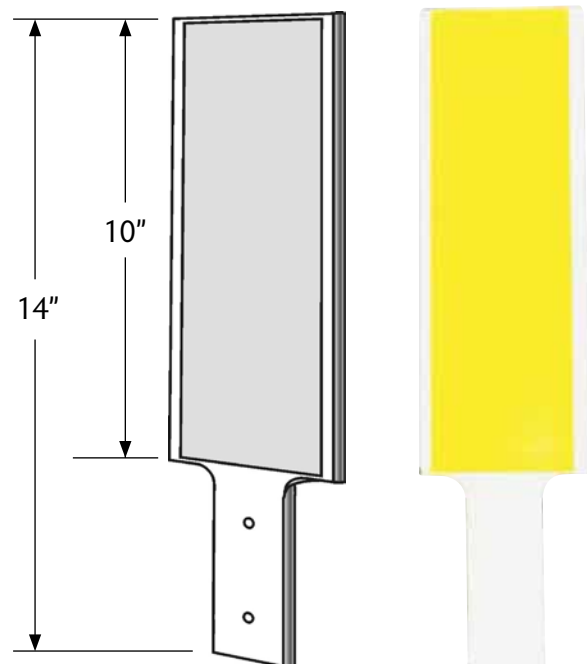

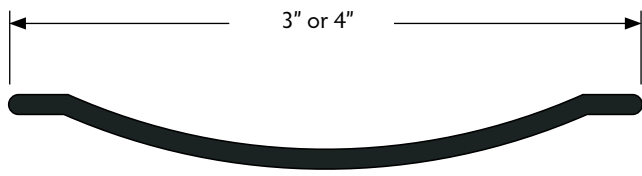

For metal, wood or concrete guardrails

Carsonite's fiberglass composite guardrail delineators add visibility to guardrails. These versatile delineators can be easily attached to wood or metal guardrails. Add reflective sheeting for enhanced visibility.

How to Order:

CGR
 4
 027
 01

Width (in.)
3 or 4

Color
(See chart below)

Product number Length (in.)

See chart for availability by color.

Color	Standard Lengths (in.)
01-White	27, 33

Other lengths and colors are available. Contact your representative.

Material: Fiberglass Composite

Options and Accessories: Stock or custom decals
Reflective sheeting



Reflective Sign Support Cover

RSC

Surface mounted, impact-resistant delineator

Carsonite's Reflective Sign Support Cover adds visibility to signs. Available in high-intensity or diamond grade reflectivity, these covers attach easily to metal or wooden posts for heightened day or night visibility—safety you can't miss.

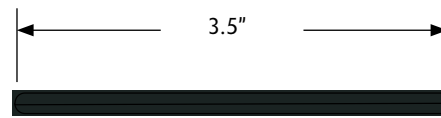

How to Order:



Color	Standard Lengths (in.)
01-White	48, 60, 72

Sheeting Color
01-White
02-Yellow
05-Red
08-Blue
10-Fluorescent Yellow Green

Other lengths and colors are available. Contact your representative.

Material: Polycarbonate
 Options and Accessories: Stock or custom decals
 Mounting Hardware



Highway Products

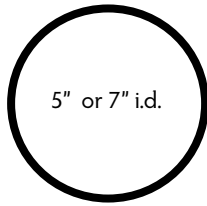

How to Order:

IGP

Product number

60

Post Size

40-4.5" or smaller
60-4.5" to 6.5"

048

Length (in.)

Color
(See chart below)

02

Color
02-Yellow

- Material: Polypropylene
-
- Options and Accessories: Reflective sheeting
Stock or custom decals

Inexpensive Solution

The Carsonite Guard Post Cover is an inexpensive solution to maintenance and visibility problems with guard posts. They offer a durable, bright yellow surface which helps to alert people to potential dangers in and around loading docks, hazardous equipment, electrical distribution, parking facilities, and gasoline dispensing and storage areas.

Simply slip the cover over the guard post for a clean, highly visible, finish. Add reflective sheeting for added visibility. Use our 40 Series for guard posts 4.5" diameter and below, and our 60 Series for posts 4.5" to 6.5" diameter.



Support Post

CSP

Durable, and easy installation

The Carsonite Support Post (CSP) is a U-channel shaped sign posts meeting the dimensions of a standard 3 lb U-channel. This post is intended for use as an object marker and a sign posts in applications requiring long-term outdoor durability, vandal resistance, and easy installation.

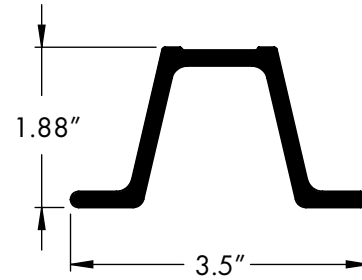

How to Order:

CSP **72** **07**
 Product number Length (In.) Color (3 choices)

Length	Color
072-72"	03-Brown
096-96"	07-Green
120-120"	09-Gray
144-144"	



03 Brown



07 Green

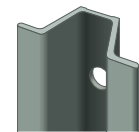

09 Gray

Material: Fiberglass Reinforced Composite

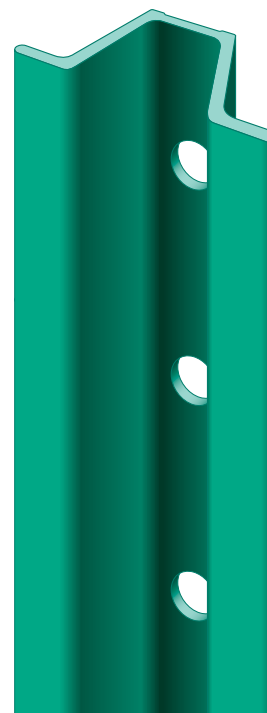



How to Order:

CSS3
Product number

072
Length (in.)
See chart for availability by color.

Color
(See chart below)
01

Color	Standard Lengths (in.)
01-White	72, 84, 96
03-Brown	72, 84, 96

Other lengths and colors are available. Contact your representative.

- Material:** Fiberglass Composite
- Options and Accessories:** Reflective sheeting
Stock or custom signs
- Installation tools:** Post Driver (PDR, PDRL)
Post Puller
Pilot Hole Driver

Great Looks and Maximum Durability

This composite post is specifically designed for use with Carsonite's composite signs up to 12" x 36". When ordered with Carsonite signs, the post can be ordered pre-drilled for ease of installation.



Hazard Marker Signs



Hazard Signs and Hazard Chevron Signs

Carsonite Hazard Markers, with 3" wide stripes, warn motorists of avoidable risks outside the designated driving lanes. Available on various reflective media and in a variety of colors and sizes, these markers enhance driver safety.

How to Order:

HM	08	24	02	06	RL	E						
Product number	Width (in.) 8, 12, 24, or 36	Length (in.) 8, 12, 24, or 36	Color 1 (See chart below)	Color 2 (See chart below)	Pattern RL or LR (see illus)*	Reflectivity E-Engineer H-Hi Intensity D-Diamond						
			<table border="1"> <thead> <tr> <th>Color</th> </tr> </thead> <tbody> <tr> <td>01-White</td> </tr> <tr> <td>02-Yellow</td> </tr> <tr> <td>04-Orange</td> </tr> <tr> <td>05-Red</td> </tr> <tr> <td>06-Black</td> </tr> </tbody> </table>		Color	01-White	02-Yellow	04-Orange	05-Red	06-Black		
Color												
01-White												
02-Yellow												
04-Orange												
05-Red												
06-Black												
<p>Standard sizes: Vertical: 8x24, 12x36 Horizontal: 24x8, 36x12</p>												

*Pattern (RL or LR) cannot be reversed by simply rotating the sign.

Material: Fiberglass Composite

Options and Accessories: Stock or custom decals

Sign Support Post

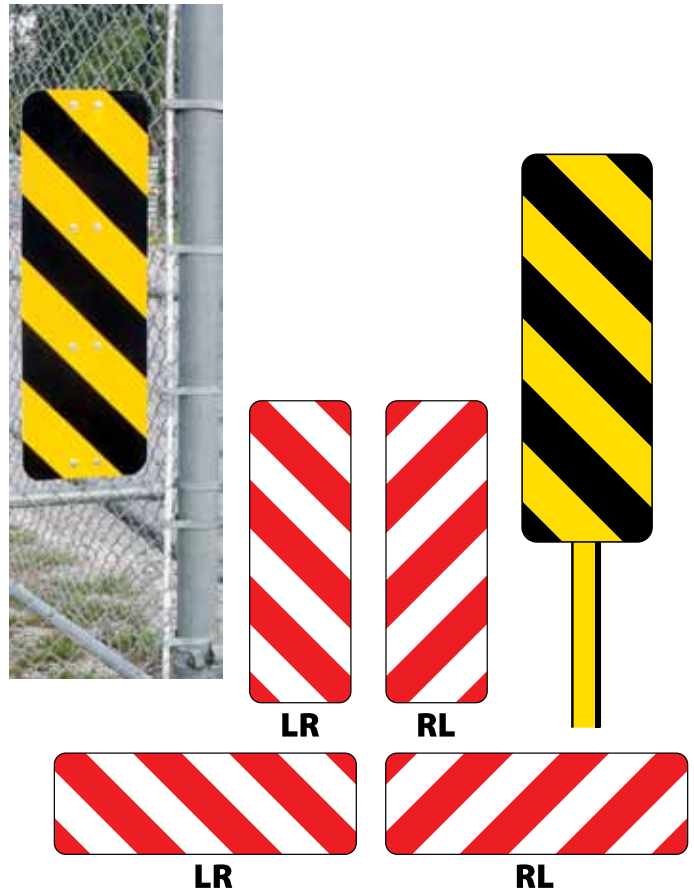

Carsonite Signs

How to Order:

(custom)
Product number

All signs are custom, including stock designs, and Product numbers are generated by the graphics department at the time of production. Please visit WWW.CARSONITE.COM to see available designs, or design your own and call us for a quote. In addition, many of our most frequently ordered signs can be purchased directly from the website by visiting WWW.CARSONITE.COM/PRODUCTS.ASP.

- Material: Fiberglass Composite
- Options and Accessories: Sign support post, Rivet tool

Stock and custom made

Carsonite's high performance composite signs are made from 0.090" or 0.135" fiberglass reinforced composite material. Available in reflective or non-reflective substrates, these signs stand up to the harshest of environments. Our state-of-the-art processes yield permanent, UV-resistant displays. With our in-house graphics department, Carsonite can help you design your sign with custom logos and phone numbers. Composite signs are available from 3" x 3" to 48" x 48". Visit us at WWW.CARSONITE.COM to see more standard and custom signage.



Carsonite Parking Signs



9186PS No Parking 12x18



9187PS ...Any Time 12x18



9188PS ...Fire Lane 12x18



9189PS ...Fire Lane 12x18



9190PS ...Between Signs 12x18



9191PS ...Between Signs 12x18



9192PS ...Any Time 12x18



9193PS ...Any Time 12x18



9194PS ...This Side 12x18



9195PS ...Fire Lane 12x18



9196PS ...Loading Zone 12x18



9197PS No Truck Parking 12x18



9203PS ...Tow Away Zone 12x18



9204PS ...Private Drive 12x18



9200PS 2 Hr Parking Visitor 12x18



9201PS 1 Hr Parking Visitor 12x18



9202PS ...Beyond This Sign 12x18



9205PS 1 Hr / Customers 12x18



9209PS Customer Only 12x18



9210PS Employee Parking 12x18



9211PS Tenant Parking 12x18



9212PS Visitor Parking 12x18



9213PS Visitor (Right) 12x18



9214PS Visitor (Left) 12x18



9218PS Visitor (Arrows) 12x18



9198PS Tow-Away Zone 12x6



9199PS Fire Lane 12x6



9215PS Employee Parking 12x18



9216PS Employee (Arrows) 12x18



9217PS Customer (Arrows) 12x18



9219PS 15 Minute Parking 12x18



9220PS 30 Minute Parking 12x18



9221PS One Hour Parking 12x18



9207PS Wrong Way 12x9



9208PS Do Not Enter... 12x21



9206PS Do Not Enter 12x12



9230PS Reserved Parking Permit Required 12x18



9232PS (Symbol) 12x12



9224PS (Symbol) 12x18



9241PS (No Parking) 18x18



9231PS Van Accessible 12x18



9229PS Parking By Permit Only 12x18



9228PS Reserved Parking (Arrows) 12x18



9237PS Violators Will Be Fined - 12x6



9236PS Permit Required 12x6



9234PS Unauthorized Vehicles... 18x12



9235PS Van Accessible 12x6

Carsonite Traffic Control Signs

Many other signs are available, as well as custom signs, including logos and custom graphics. Contact your representative.



8620CR
(Crossing)
8x8



9238PS Do
Not Enter
18x18



9239PS
(No Left)
18x18



9240PS
(No Right)
18x18



9242PS
(No Truck)
18x18



9243PS
(Symbol)
18x18



9244PS
Slow
18x18



9245PS
Bump
18x18



9246PS
Caution
18x18



9247PS Exit
(Right)
18x18



9248PS
Exit (Left)
18x18



9250PS Exit
Only...
12x18



9249PS
Exit Only
18x18



9252PS
Enter Only
18x18



9258PS Enter
(Right)
18x18



9259PS
Enter (Left)
18x18



9253PS No
Left Turn
12x18



9260PS
Keep Right
12x18



9261PS
Keep Left
12x18



9262PS
One Way
(Right)
18x18



9263PS One
Way (Left)
18x18



9254PS No
Right Turn
12x18



9256PS Speed
Limit 5
12x18

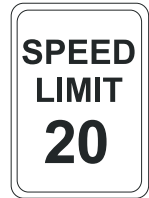

9255PS Speed
Limit 20
12x18



9257PS Speed
Limit 10
12x18



9264PS
One Way (Arrow
Right)
18x6



9265PS
One Way (Arrow Left)
18x6



8540RR
Rough Road
12x12



8620CR
(Symbol)
18x18



8448STOP
Stop
18x18



9251PS
Employee
Entrance
12x18



Reflective Sheeting

Enhance Visibility

Carsonite offers a full array of reflective media that can be permanently applied to your posts at the factory or shipped separately. Standard widths are 3.0", but others are available on special order—contact your representative.

Reflective Sheeting is available in three grades:

- Engineer Grade (RSE30) Type I
- Hi Intensity (RSH30) Type III/IV
- Diamond Grade (RSD30) Type VIII



How to Order:

ENGINEER GRADE 3"

RSE30
Product number

12
Length (in.)
See chart for availability by color.

Color
(See chart below)
04

Color
01-White
02-Yellow
04-Orange
05-Red
06-Black
08-Blue

Other lengths and colors are available. Contact your representative.

HI-INTENSITY 3"

RSH30
Product number

12
Length (in.)
See chart for availability by color.

Color
(See chart below)
10

Color
01-White
02-Yellow
05-Red
07-Green
08-Blue
10-Fluorescent Yellow/Green

Other lengths and colors are available. Contact your representative.

DIAMOND 3"

RSD30
Product number

06
Length (in.)
See chart for availability by color.

Color
(See chart below)
10

Color
01-White
02-Yellow
05-Red
07-Green
08-Blue
10-Fluorescent Yellow/Green

Other lengths and colors are available. Contact your representative.

Material: Vinyl or Reflective Media

Options and Accessories: Flat or Round Markers
Visibility Enhancers

Carsonite Decals

How to Order:

(custom)

Product
number

Product numbers are generated by the graphics department at the time of production. Please visit WWW.CARSONITE.COM to see available designs, or create your own and call us for a quote. In addition, many of our most frequently ordered decals can be purchased directly from the website by visiting WWW.CARSONITE.COM/PRODUCTS.ASP.

Stock and custom made

Conveying the proper message is at the heart of your marking needs. Carsonite offers a wide selection of standard decals on both reflective and non-reflective media. These pressure-sensitive, UV- and weather-resistant decals can be ordered in a wide variety of colors and sizes. Personalize your marking with custom decals displaying your company name, logo, and phone number. With over 30 years of experience, Carsonite's in-house graphics department can help you design any custom decal. When ordered with Carsonite posts, the decals can be applied for you at the factory.

Material: Vinyl or Reflective Media

Options and Accessories: Flat or Round Markers



KEEP RIGHT



**SHORT TERM
PARKING**

FIRE LANE

BUSSES ONLY

COMPACTS ONLY

VISITORS

TAXI ONLY

RESERVED



HANDICAPPED ONLY

NO PARKING

NO TENTER

REGISTRATION

KEEP LEFT

EXIT

FOR LEFT

RESERVED

MGS

Modular Guidance System™

Blades:



NMGS Base Rail:

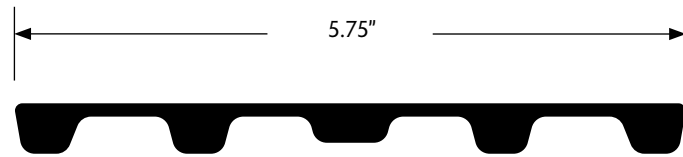

WMGS Base Rail:



Material: Fiberglass Composite

Options and Accessories: Reflective Sheeting

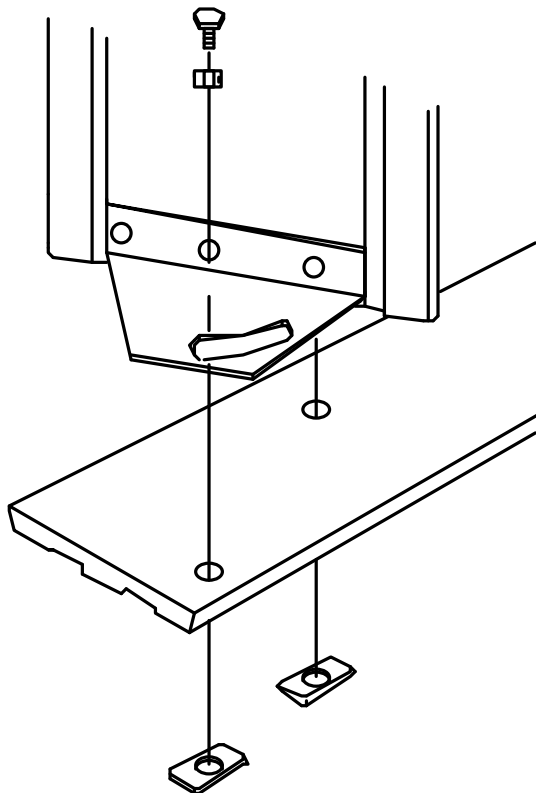

Blades can be attached to base rail before going on site.

For excellence in work safety

Carsonite's Modular Guidance System is designed to block blinding headlight glare from opposing traffic lanes. This anti-glare screen comes with a base rail system that allows quick and simple installation, limiting the amount of time workers spend installing the system. The base rail units come pre-sized for 10, 12, 12.5 and 15' barriers. The blades, available in various heights, are adjustable up to 22 degrees to optimize cut-off angle. In addition, Carsonite's MGS prevents motorists from impeding traffic flow by gawking into construction zones. The system efficiently and safely guides motorists through the zone.

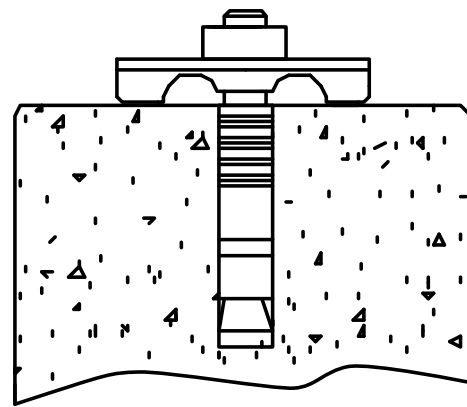

Base rail attachment hardware included.



For work zone and permanent barriers

MGS

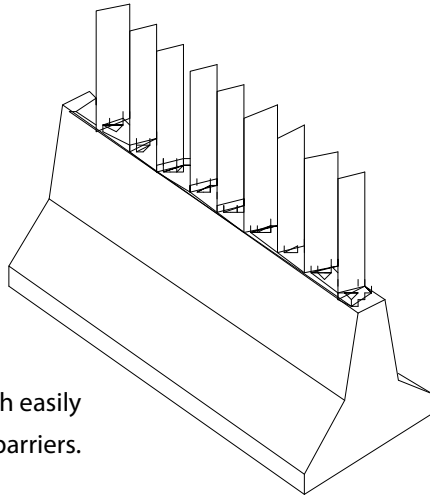

Modular sections attach easily to concrete barriers.

How to Order:

N M G S

Product number

NMGS
WMGS

Other lengths and colors are available. Contact your representative.

118

Barrier Length (in.)

118-10' Barrier
142-12'
150-12.5'
178-15'

24

Blade Length (in.)

18"
24"
30"

Blade Color (Green)

07

Bracket Material

G-Galvanized
S-Stainless steel

G



Carsonite AcoustaShield™ Sound Barriers

How to Order:

Contact your representative or visit www.carsonite.com to request more information and an AcoustaShield information packet.

- ▶ Meets AASHTO and DOT sound wall guidelines
- ▶ Low maintenance over life of product
- ▶ Wide variety of colors available
- ▶ Spans up to 18 feet
- ▶ Graffiti resistant
- ▶ Lightweight, easily installed with minimal equipment
- ▶ Non-conductive fiberglass supports and panels

Effective against noise and light pollution

Carsonite's AcoustaShield Sound Barrier provides noise abatement along transportation corridors, as well as other applications requiring long-term outdoor durability, vandal resistance and ease of construction.

Easily customized, the system lets you design your sound barrier to fit your specific needs. Choose from unfilled, recycled-rubber filled, or absorptive options. These lightweight panels can be installed by a small crew without the use of heavy lifting equipment. The flame retardant panels can be easily cut in the field if on-site adjustments are needed. For applications under 15' in height, inquire about our fiberglass uprights.

Highest performance, best looking, and easiest to install and maintain

Material: Fiberglass composite

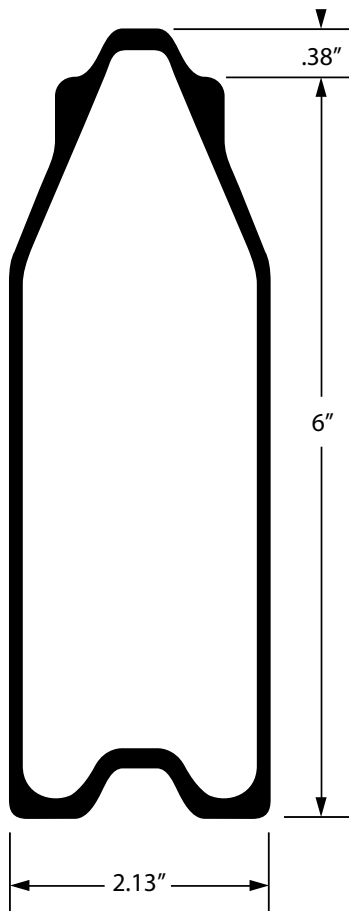

Ratings			
	AcoustShield Absorptive	AcoustaShield Filled	AcoustaShield Unfilled
STC Rating	28	37	28
NRC Value	.95	.15	.20



At only 5 to 7 pounds per square foot, AcoustaShield does not add unnecessary weight to bridge structures.

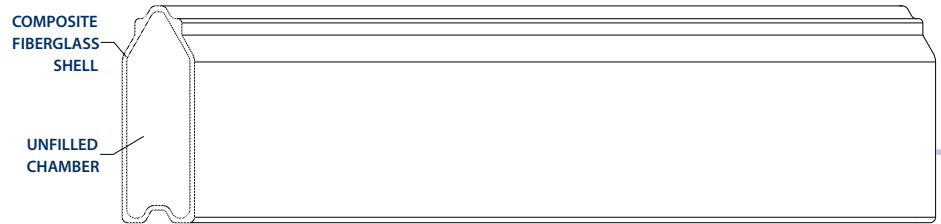

FIGURE 1 UNFILLED

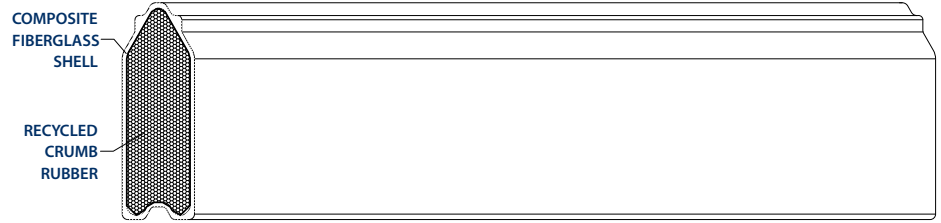

FIGURE 2 RUBBER FILLED

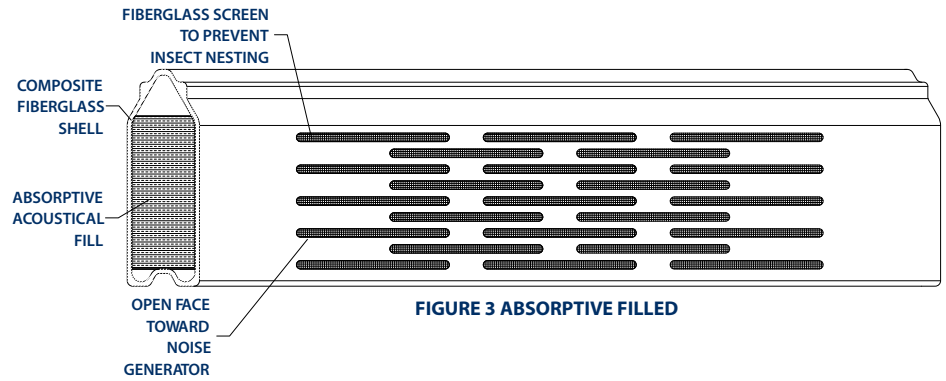

FIGURE 3 ABSORPTIVE FILLED



Carsonite AcoustaShield™ Sound Barriers



Carsonite sound barrier planks are adjustable and can be easily cut in the field.

A two-person crew can install 180 square feet in less than five minutes after uprights are set.



AcoustaShield

By Carsonite



AcoustaShield™ is ideal for highways, mass transit lines, residential roads—any place where noise is a problem.

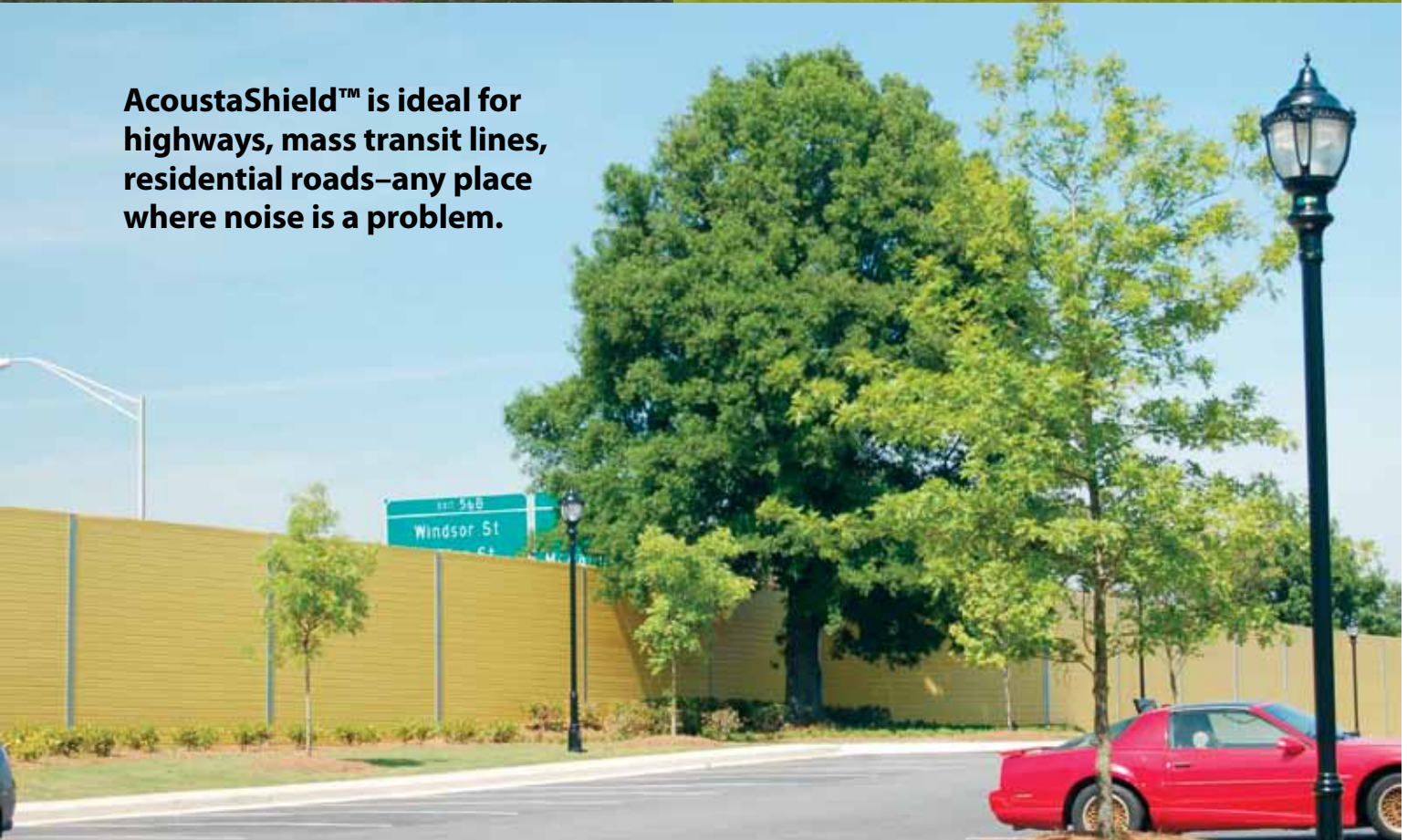

Beautify the busiest of highways.

Highway Products

Installation Tools

How to Order:

Post Driver

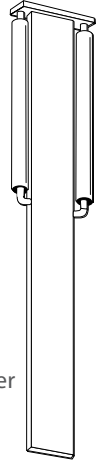
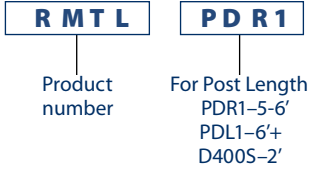

Guide Tube



Post Driver

Sentry Socket Driver



Sentry Socket Driver

Utility ID Driver



Utility ID Driver

Pilot Hole Driver



Pilot Hole Driver

U-Channel Driver



U-Channel Driver

Post Puller



Post Puller

Material: Welded Steel

For all soils and applications

Carsonite's Standard Post Driver (PDR1) is used to install Utility Marker, Tuff-Flex™, Curv-Flex™, Dual-Sided Marker and GreenLine™ Single Curve Marker. 48" in length, this driver is for posts from 5 to 6 feet long.

Carsonite's Long Post Driver (PDL1) is used to install Utility Marker, Tuff-Flex, Curv-Flex, Dual-Sided Marker and GreenLine Single Curve Marker. At 56" in length, it is for posts over 6' long.

Carsonite's Short Post Driver (D400S) is used to install Utility Marker, Tuff-Flex, Curv-Flex, Dual-Sided Marker and GreenLine Single Curve Marker. At 24" in length, this driver is for posts under 5' long.

The Sentry™ Socket Driver (RMTLDSMD10) is for installing Sentry post sockets.

The Guide Tube (RMTLPGT1) gives an added assist in keeping posts vertical during installation. Also useful in preventing posts from flexing when installing into hard or rocky soil. The Guide Tube is useful with RMTLPDR1 or RMTLPDL1 drivers.

Utility ID Post Driver (RMTLD250). This accessory is intended for use with the Utility ID Post (CBM).

The U-Channel Driver (RMTLDSD300) is intended for installing Carsonite's Curv-Flex or other Carsonite markers that utilize the U-Channel option.

The Pilot Hole Driver (RMTLDP100) is for use in hard or rocky soil when driving posts can be exceedingly difficult. The driver's spaded head leaves a hole to assist in driving the post. For use with all Carsonite markers.

Carsonite's Post Puller (RMTLCPP) is used to remove posts that may need replacing. Use the Post Puller with any of our flat markers.

Other specialized tools are also available. Contact your representative.



ANCHOR BARBS

Protection from theft

Anchor barbs are intended to prevent the post from being pushed out of the ground during freeze/thaw cycles, as well as from attempts to pull them out by would-be vandals. Anchor barbs are available in polycarbonate. Purchase in packs of 10 or have them factory installed when ordering posts.



How to Order:

Composite Anchor Barb
(Installed at Factory)

Composite Anchor Barb
(loose, 10 pcs, including rivets)

ANCBARU

ANCBARPK

Product number

Product number



<http://carsonite.com/highway.asp>



19845 U.S. Highway 76
Newberry, South Carolina 29108
800-648-7916 · f/803-276-8940 · www.carsonite.com